

# Classic Update Series

1957 CHEVY

## START HERE !

PLEASE READ THIS BEFORE STARTING INSTALLATION !

This wiring kit is designed for ease of installation. Please read the guidelines below, BEFORE STARTING your installation to guarantee a successful job. Use appropriate crimping tools, which fold the wings of the open barrel terminals down into the wire, as shown below. Our crimping set 510587 is recommended. ALL TERMINALS not crimped with the 510587 tools SHOULD BE PROPERLY SOLDERED. Our factory crimped terminations are installed by GM approved five ton presses, and soldering these terminations is not necessary. AAW offers a great terminal crimping video entitled which can be viewed by visting YouTube at this web address: <https://youtu.be/JAgEDoVI-co?feature=shared>



**AS THIS HARNESS IS DESIGNED FOR USE IN A MODIFIED CAR REQUIRING A HIGHER RATE OF CHARGE, IT DOES NOT SUPPORT THE USE OF A STOCK (ORIGINAL) GENERATOR. IT IS DESIGNED FOR USE WITH AN INTERNALLY REGULATED "SI" OR SINGLE WIRE STYLE ALTERNATOR. IT CAN ALSO BE USED WITH THE LATER "CS" AND "CS-D" UNITS BY USING ALTERNATOR ADAPTERS WHICH ARE SOLD SEPARATELY. CONTACT AAW OR YOUR FAVORITE DEALER FOR THE PROPER ALTERNATOR ADAPTER FOR YOUR CAR.**

### STEP 1: DISCONNECT YOUR BATTERY:

Disconnect the battery before installing the wiring kit to prevent any accidental shorting caused by loose bare wire ends.

### STEP 2: START INSTALLING KIT:

This kit is broken down into individual steps that are identified by a letter printed on instruction pages visible through each bag. These letters are the order of operation for installing your kit. Start with the bag letter "G", then "H", etc. The order of installation is shown below.

G	500433	Dash Harness Kit
H	510409	Gauge Cluster Kit
J	510405	Engine Kit
K	510410	Park / Headlamp Connection Kit
L	500432	Front Light Kit
M	510404	Rear Body Kit
N	500471	Courtesy Light Connection Kit
Z	510476	Alternator and Main Connection Kit

### STEP 3: RECONNECT YOUR BATTERY:

When you have completed the installation and are ready to reconnect the battery, make sure that the following electrical system grounds are in place:

- Battery is grounded to the ENGINE BLOCK.
- Battery is grounded to the frame.
- Engine block is grounded to the frame.
- Body is grounded to the frame.

### STEP 4: CHECK ALL ELECTRICAL FUNCTIONS:

Any non-functioning items should be checked for proper installation. Any problems with your wiring and electrical circuit functions should be addressed to American Autowire Systems, Inc. as soon as possible to avoid any warranty problems.

If you have any questions concerning this or any of our products, please feel free to call us at 1-800-482-WIRE.

"AMERICAN AUTOWIRE MAKES IT EASY !!!"

100% MADE IN U.S.A.!!

also available from  
American Autowire

Hood & trunk lights  
Door jamb switches  
Custom battery cables  
Master disconnect switch  
Adjustable Fuel Warning Module  
Terminals, connectors, grommets, light sockets  
Billet turn signal knobs  
Neutral safety switch  
Glove box light  
LED lights  
...AND MUCH MORE !

### OPTIONAL ACCESSORY KITS

Brake Switch	p/n 500097	Universal, Button type, 2 blade contact to operate brake lights.
Brake Switch	p/n 500145	Universal, Button type, 4 blade contact to operate brake lights & cruise control / lock up converter.
Universal Relay Kit	p/n 500479	Complete relay kit with wiring and relay.
Wiper Switch	p/n 500146	Universal, two speed wiper switch.
Ignition Sw. Tumbler	p/n 500672	New tumbler and key for your new Classic Update or stock original 1957 ignition switch.
Convertible Top Kit	p/n 500444	Power top wiring from power source to switch to motor assembly, complete.
Turn Signal Switch	p/n 37789	1957 Stock turn signal switch.
License Lamp Kit	p/n 34635	License Plate Light Assembly
Assembly Manual	p/n 36316	1957 Factory assembly manual.
Grille Bar Grommet & Connector kit	p/n 500548	1957 Front splash pan grommet and connector kit for grille bar and horns.



**American  
Autowire**

www.americanautowire.com 856-933-0801

PART #  
**500434**

DESCRIPTION:

**FULL VEHICLE WIRING KIT  
1957 CHEVROLET**

92965107 Rev 8.0 08/15/2024

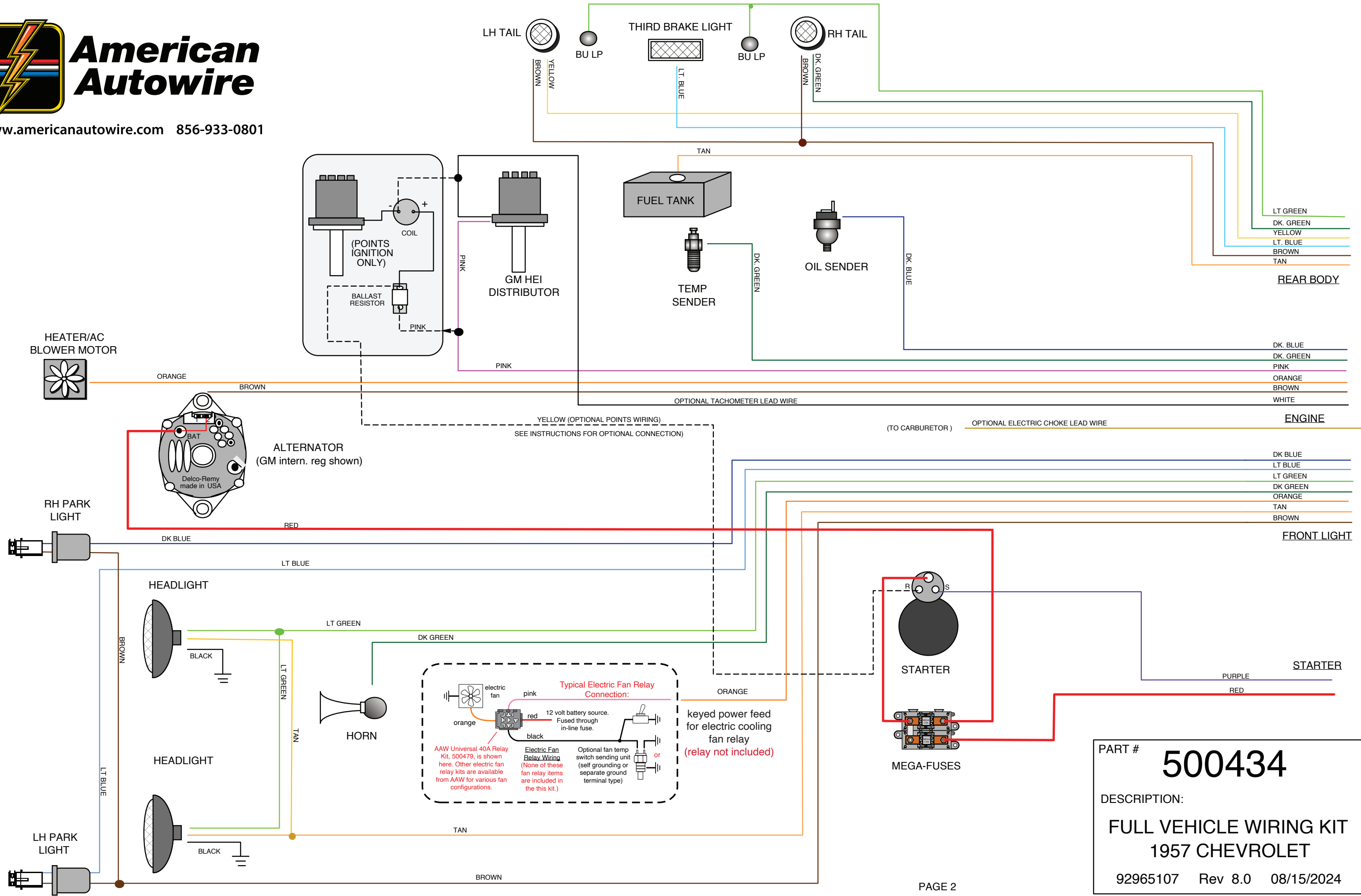

PART # **500434**

DESCRIPTION:  
**FULL VEHICLE WIRING KIT  
1957 CHEVROLET**

92965107 Rev 8.0 08/15/2024



# American Autowire

www.americanautowire.com 856-933-0801

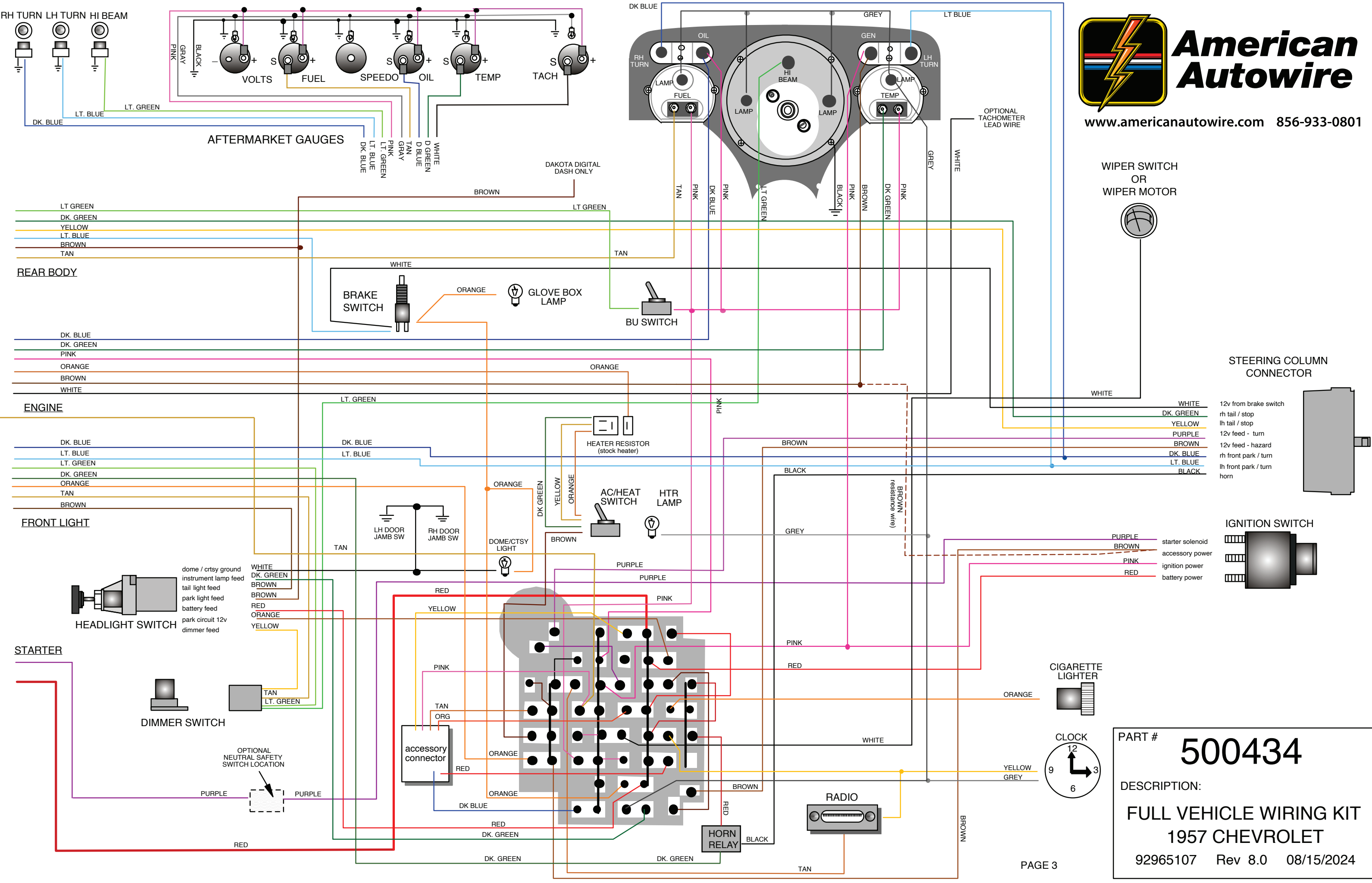

WIPER SWITCH OR WIPER MOTOR



STEERING COLUMN CONNECTOR

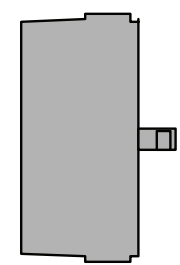

- WHITE 12v from brake switch
- DK. GREEN rh tail / stop
- YELLOW lh tail / stop
- PURPLE 12v feed - turn
- BROWN 12v feed - hazard
- DK. BLUE rh front park / turn
- LT. BLUE lh front park / turn
- BLACK horn

IGNITION SWITCH



- PURPLE starter solenoid
- BROWN accessory power
- PINK ignition power
- RED battery power

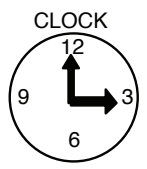
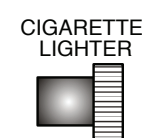

PART # **500434**

DESCRIPTION:  
**FULL VEHICLE WIRING KIT  
1957 CHEVROLET**

92965107 Rev 8.0 08/15/2024

THIS PAGE HAS BEEN  
INTENTIONALLY LEFT BLANK



[www.americanautowire.com](http://www.americanautowire.com) 856-933-0801

PART #	<b>500434</b>
DESCRIPTION:	FULL VEHICLE WIRING KIT 1957 CHEVROLET
92965107	Rev 8.0 08/15/2024